



Pro Scale® Advanced Lighting Control System Installation Instructions - TRX-4® Sport

Covers Part #8085X

The Traxxas Pro Scale® Advanced Lighting Control System for your TRX-4® Sport consists of two major electronic components: the Pro Scale Lighting Power Module and the Pro Scale Lighting Distribution Block.

The Lighting Power Module installs on the chassis and performs as the voltage regulator and power supply for the lighting system. It also controls various lighting functions through the two buttons on the face of the module and communicates with the receiver in the model via the communication cable *or* the optional included MAXX® Link cable.

The Lighting Distribution Block mounts in the body of the vehicle and is the distribution hub for all the various wired lights in your Sport body. Its main function is to direct power and instructions to the brake lights, reverse lights, turn signals, and high/low beam lighting.

There is only one rugged breakaway wiring connector between the Lighting Distribution Block and the Lighting Power Module for reliable lighting performance, plus it makes it easy to remove the body for vehicle service. The connector is designed to break away from the vehicle, without damage, if the body comes off the vehicle in a crash. There are lighting channels on the Lighting Power Module which allow the lighting installed on the chassis to be permanently connected and integrated into the system. This is helpful to install features such as rock lights, bumper lights, and other chassis-mounted accessory lighting.



CAUTION: RISK OF INJURY!

Use care with hobby knives, tapered reamers, and other cutting tools as they are extremely sharp and can cause severe injury, deep cuts, and/or punctures.



CAUTION: RISK OF DAMAGE TO BATTERIES!

Always disconnect the battery from the ESC when not in use to prevent the possibility of over-discharge and battery damage.

Kit Contents:

- Pro Scale Lighting Power Module
- Power module chassis mount
- Pro Scale Lighting Distribution Block
- Lighting Distribution Block mount
- Motor sense wire harness
- Breakaway cable (part of the Lighting Distribution Block)
- MAXX® Link cable (Data Link) (TQi Radio System only)
- Receiver communication cable
- Headlights harness assembly
- Tail lights harness assembly
- Turn signal harness
- Reverse lights harness
- Front grille
- Front grille retainer
- Headlight clamps (2)
- Tailgate panel
- Tailgate panel retainer
- Tail light clamps (2)
- Reverse light lens, left & right
- Jumper
- LED front bumper light bar high/low adapter
- LED roof light bar high/low adapter
- 2.5x8mm button-head screws (8)
- 2.6x8mm button-head screws (4)
- 2.5x10mm button-head screws (2)
- 2.5x10mm countersunk cap screw (1)
- 2.5x12mm cap screw (1)
- 2.5x18mm cap screw (1)
- Zip ties (10)
- Zip tie mount (3)
- Body templates
- Double-sided adhesive foam tape
- Silicone grease

Tools required:

- Safety glasses
- 2.0mm hex wrench (part #3415, sold separately)
- 1.5mm hex wrench (part #3415, sold separately)
- Hobby knife
- Small file (optional)
- Tapered body reamer (part #3433 or #3433X, sold separately)
- Body scissors (part #3431 (straight tip) or #3132 (curved tip), sold separately)
- Rotary tool (such as Dremel®) (optional)
- Wire cutters (to trim zip ties)
- Small needle nose pliers

LIGHTING DISTRIBUTION BLOCK

Accessory Connectors
(not used with this kit)

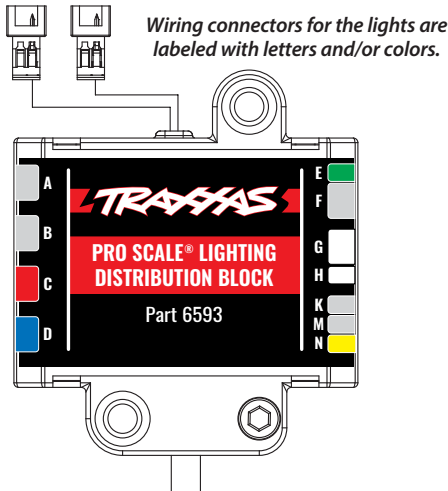

LIGHTING POWER MODULE

to Traxxas XL-5 HV Electronic Speed Control (ESC) or direct battery power source up to 3s LiPo or 12.6V

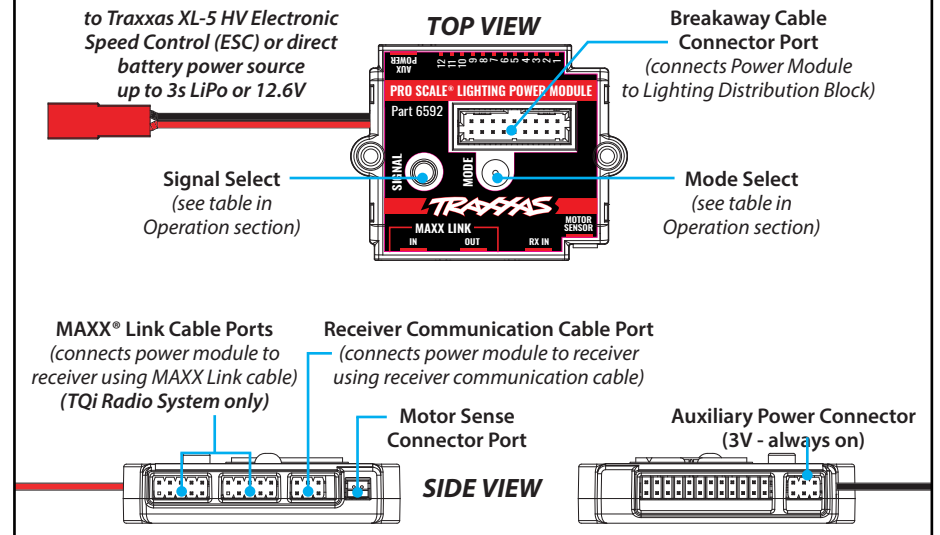

COMMUNICATION CABLES

Your Pro Scale Advanced Lighting Control System includes two communication cables: the Receiver Communication Cable and the MAXX® Link Cable.

Since your TRX-4 Sport is factory equipped with the TQi receiver, use the Receiver Communication Cable to connect the Lighting Power Module to the receiver.

The MAXX Link Cable is only for use on models with the TQi radio system.

The 6511 Traxxas Link Wireless Module (sold separately) is required for Traxxas Link App functionality (only with the MAXX Link Cable). Some models may require a software update for the TQi receiver via the Traxxas Link App for custom lighting controls and configurations (see Appendix on page 7 for additional information).

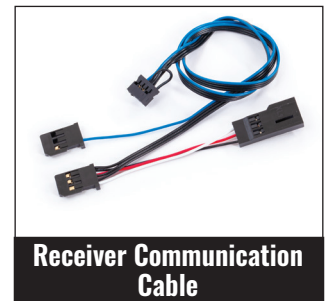

A. INSTALL THE LIGHTING POWER MODULE ON THE CHASSIS

1. Install the Power Module mount on the chassis with the included 2.5x10mm countersunk cap screw (Fig. 1).
2. Install the Lighting Power Module on the mount with the included 2.5x12mm (1) and 2.5x18mm (1) cap screws (Fig. 1).
3. Route the module power wire under the mount. Plug the red male connector from the ESC into the red female connector from the power wire (refer to the Chassis Wiring Diagram on page 3 for more detail).

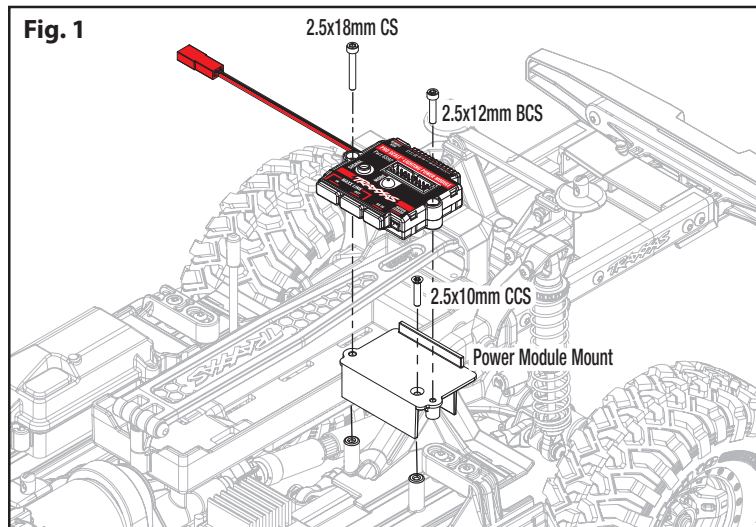

B. WIRE THE LIGHTING POWER MODULE TO THE RECEIVER

1. Plug one end of the Receiver Communication Cable into the RX IN port on the Power Module (Fig. 2) (refer to the Chassis Wiring Diagram on page 3 for more detail).



2. Remove the 3x10mm counter-sunk cap screws (2) from the battery tray (Fig. 3).
3. Lift up the battery tray and route the Receiver Communication Cable from the Power Module under the battery tray and to the receiver box (refer to the Chassis Wiring Diagram on page 3 for more detail). Use a zip tie (included) to attach the wires to the loop on top of the transmission housing. Reinstall and tighten the battery tray screws. **Note: Be careful not to pinch or damage any of the wires under the battery tray.**

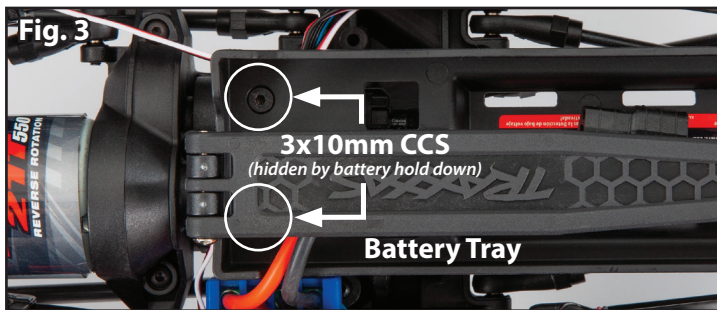

4. Remove the receiver box cover by removing the three 3x8mm button-head cap screws (Fig 4).
5. Remove the wire clamp by removing the two 2.5x8mm cap screws (Fig 4).
6. Feed the loose end of the Receiver Communication Cable connector over the wire guide and into the receiver box (Fig. 5). To make installation easier, unplug and remove a few of the existing wires from the receiver box.

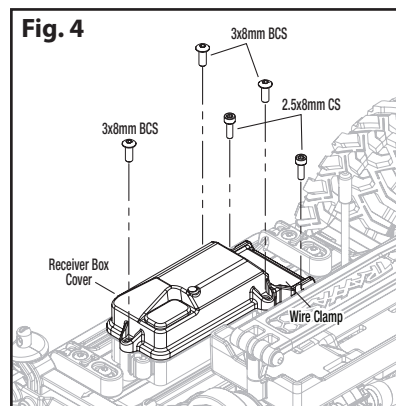

Note the locations of any unplugged wires.

Use needle nose pliers to help grab the connectors and pull them through. Arrange all wires neatly between the wire guides in the receiver box (Fig. 5). The excess wire will be bundled inside the receiver box.

7. Apply a bead of the included silicone grease to the wire clamp (Fig. 6).
8. Be careful not to damage the wires (make sure the wires are in the wire guides). Reinstall the wire clamp. Tighten the two 2.5x8mm cap screws securely (Fig. 7).
9. Unplug the electronic speed control (ESC) from the receiver (channel 2).
10. Plug the communication cable into the receiver (Fig. 8): the black connector with the single blue wire plugs into one of the channel 1 ports; the female black connector with the 3 black wires plugs into the channel 2 port.

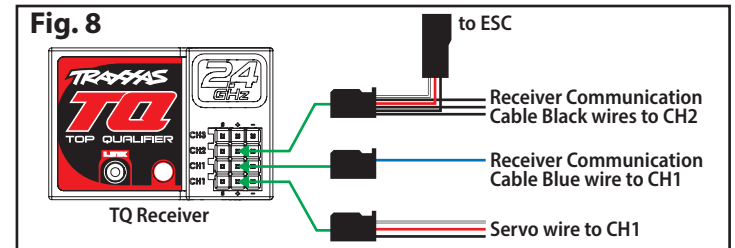
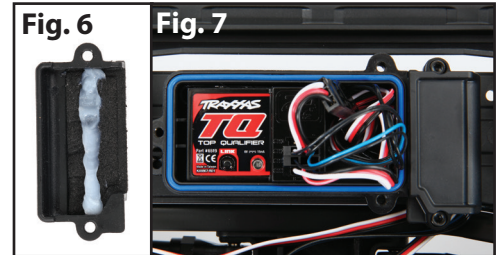

11. Now, plug the black male connector (white, red, black servo cable) from the ESC into the black female connector (white, red, black servo cable) on the communication cable (refer to the Chassis Wiring Diagram on page 3 for more detail). Leave the steering servo cable plugged into the other channel 1 port.
12. Make sure the blue o-ring gasket is properly seated in the groove in the receiver box so that the cover will not pinch it or damage it in any way.
13. Reinstall the cover on the receiver box and tighten the three 3x8mm button-head cap screws securely. Inspect the cover to make sure that the O-ring seal is not visible.
14. Use the supplied zip ties to bundle the wires neatly and attach them to the vehicle as needed so that loose wires will not become entangled with moving parts.

C. WIRE THE FRONT BUMPER LIGHT BAR TO THE POWER MODULE

1. If the front bumper light bar is installed on the chassis, plug the light bar wire harness connector (black wire only) into the included high/low adapter (Fig. 9).
2. Plug the other light bar wire harness connector (blue and black wires) into the channel 3 port and the high/low adapter connector into the Channel 4 port on the Power Module (Fig. 10) (refer to the Chassis Wiring Diagram on page 3 for more detail). Use zip ties and the existing wire clips to secure the wiring to the chassis rail.

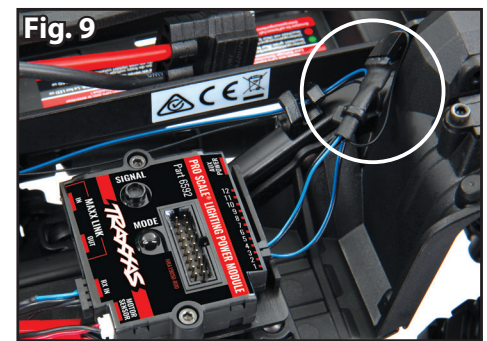

D. INSTALL THE MOTOR SENSE WIRING HARNESS

1. Unplug the red and black motor wires (bullet connectors) from the ESC. Plug the bullet connectors from the motor and the ESC into the motor sense wiring harness (red to red and black to black) (Fig. 11). Plug the harness connector into the *Motor Sensor* port on the power module (refer to the *Chassis Wiring Diagram* on page 3 for more detail).
2. Use the supplied zip ties to bundle the wires neatly and attach them to the vehicle as needed so that loose wires will not become entangled with moving parts.

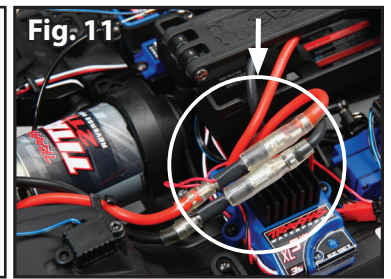
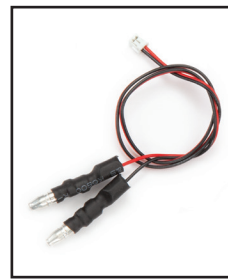

CHASSIS WIRING DIAGRAM

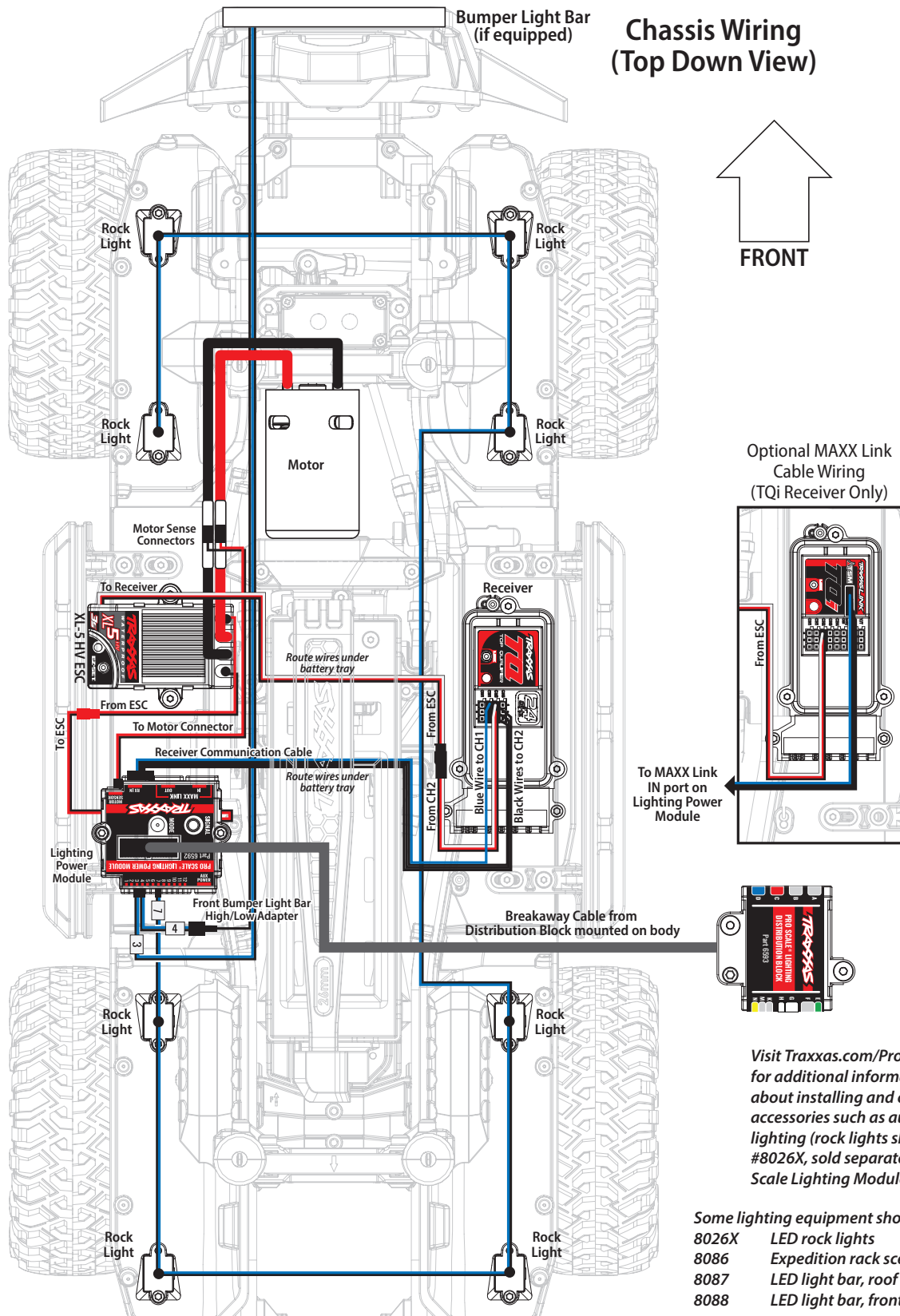

Visit Traxxas.com/ProScaleLighting for additional information about installing and connecting accessories such as auxiliary lighting (rock lights shown, part #8026X, sold separately) to the Pro Scale Lighting Module.

- Some lighting equipment shown sold separately:
- 8026X LED rock lights
 - 8086 Expedition rack scene lights
 - 8087 LED light bar, roof lights
 - 8088 LED light bar, front bumper

E. MODIFY THE BODY

1. Install the included templates on the body. Align the arrows with the body lines on the front grille and the tailgate as shown in Fig. 12 and 13.
2. Using a tapered body reamer, carefully cut the holes in the truck body for the screw bosses on the front grille retainer and the tailgate panel (*note the hole diameters indicated on the templates and the corresponding diameter measurements on the body reamer*).
3. Using a hobby knife, carefully cut out the holes in the truck body for the headlight housing and the tail light lens.

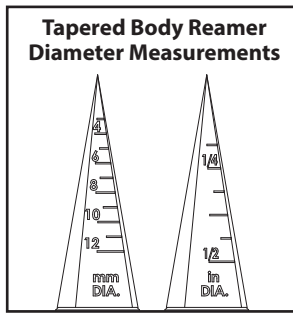
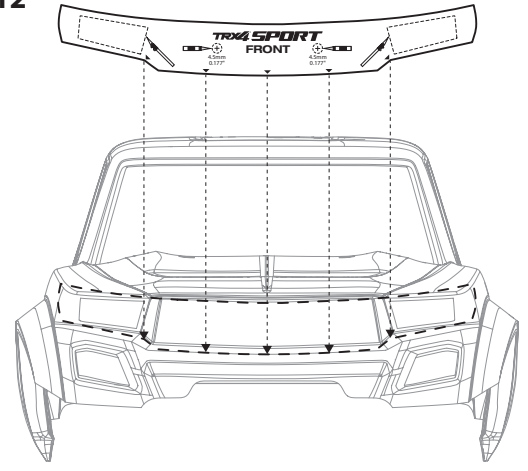

Fig. 12



Tip: If you have a rotary tool (such as Dremel®), then use a small routing bit to cut out the openings. Start by using the tapered reamer to make a small hole inside the area to be removed. Insert the routing bit into the hole, and then follow the cut out lines. **CAUTION: Wear your eye protection when using the motorized tool!** Use a hobby knife or a small file to carefully trim the corners square. When using a hobby knife, score the body material several times with the knife blade, and then snap it over to break and release. This will provide the cleanest cuts. Do not try to cut all the way through the body material in one pass or “saw” it with the knife blade.



CAUTION: RISK OF INJURY!

Use care with hobby knives, tapered reamers, and other cutting tools as they are extremely sharp and can cause severe injury, deep cuts, and/or punctures.

F. INSTALL LED LIGHTS

Note: While installing the LED lights, install the included zip tie mounts and use zip ties to secure the wiring to the body in the locations provided (*refer to the Lighting Assembly Diagram below and the Body Wiring Diagram on page 6 for more detail*). The zip ties do not need to be tight; allow some slack for wire movement.

1. Install the front grille (A) with the front grille retainer (B), headlight clamps (C), tailgate panel (D) with the tailgate panel retainer (E), and tail light clamps (F) on the truck body using the included hardware.
2. Insert the headlight LEDs (G) and tail light LEDs (H) into the receptacles of the headlight clamps and tail light clamps. Be careful not to damage the wires. The LEDs should snap into place.
3. Insert the reverse light LEDs (I) (harness labeled for distribution block port A) and turn signal LEDs (J) (harness labeled for distribution block port B) into the receptacles in the tailgate panel. The LEDs should snap into place. Route both harnesses alongside the existing wiring in the truck body (*see Body Wiring Diagram on page 6 for correct LED locations; reverse lights to the inside, turn signals to the outside*).

Fig. 13

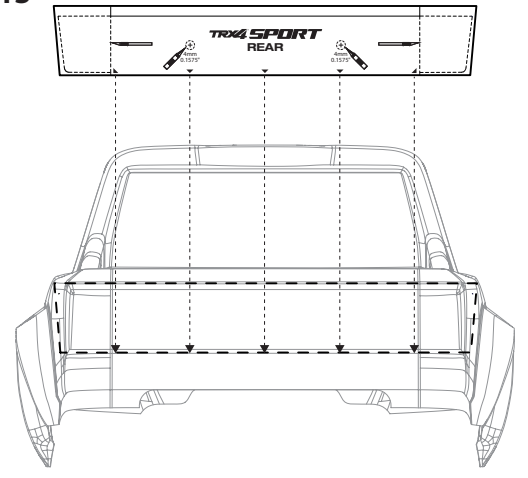

LIGHTING ASSEMBLY DIAGRAM

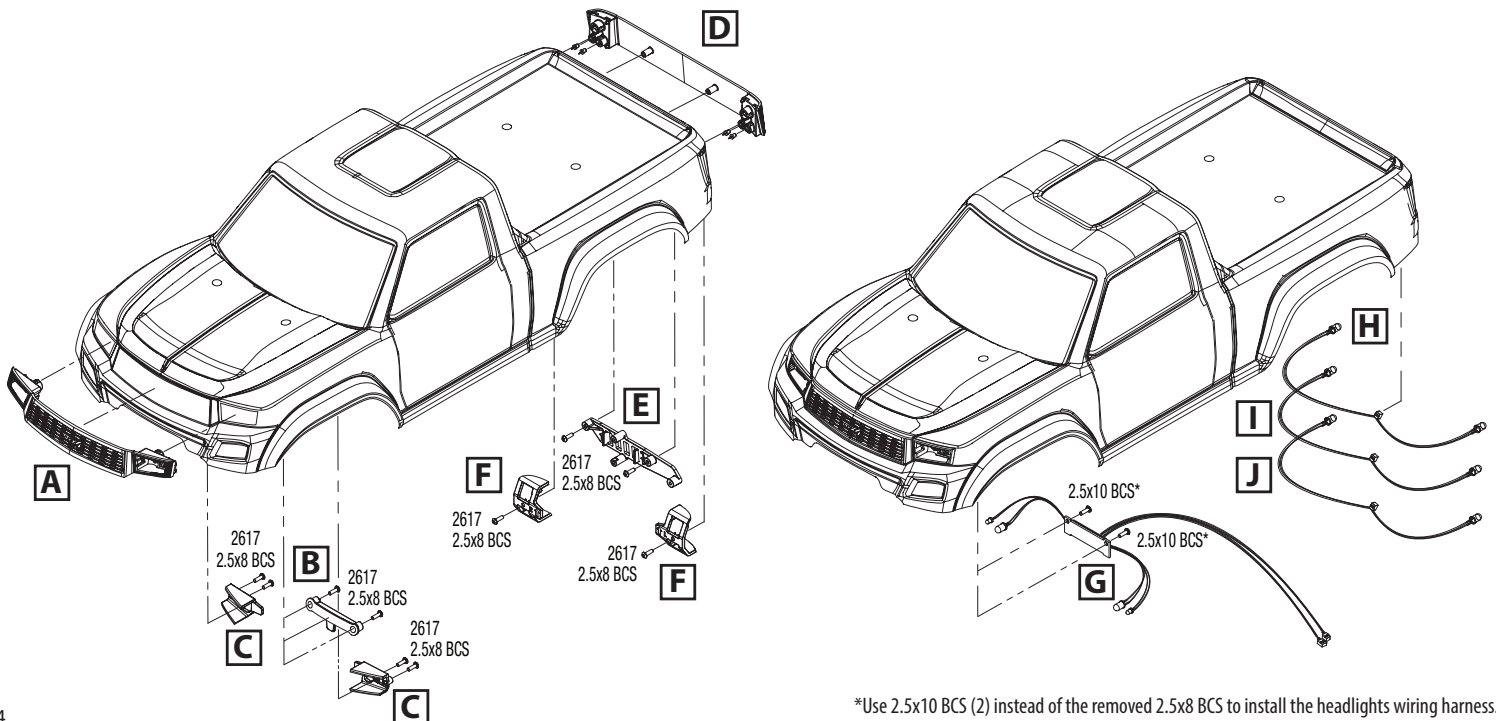

*Use 2.5x10 BCS (2) instead of the removed 2.5x8 BCS to install the headlights wiring harness.

G. INSTALL THE DISTRIBUTION BLOCK

1. Peel the backing from one side of the included adhesive foam tape and attach it to the underside of the Lighting Distribution Block mount as shown in Fig. 14. Do not remove the backing from the other side of the tape yet.
2. Install the Lighting Distribution Block mount on the tailgate panel retainer and secure it with the 2.6x8 mm button-head screws (2) (Fig. 14).
3. Gently flex the body away from the Lighting Distribution Block mount and remove the backing from the other side of the foam tape. Press the body against the mount to adhere it to the mount.
4. Plug the LED roof light bar harness (with a yellow color band near the connector) (if installed) into the included high/low adapter (labeled for distribution block port M) (Fig. 15) (see *Body Wiring Diagram on page 6*).
5. Plug the connectors from the LED light wire harnesses and the high/low adapter on the truck body into the ports on the distribution block. Match the color band and/or letter indicator on the harnesses with the corresponding color/letter of each port on the Lighting Distribution Block (refer to the *Distribution Block port chart below for more detail*). Plug the scene lights harness (if installed) into port N. Install the included single jumper into port E.
6. Use the included 2.6x8mm button-head screws (2) to secure the distribution block to the mount (Fig. 14).
7. Plug the breakaway cable from the Lighting Distribution Block into the connector on top of the Power Module before installing the vehicle body (Fig. 16).

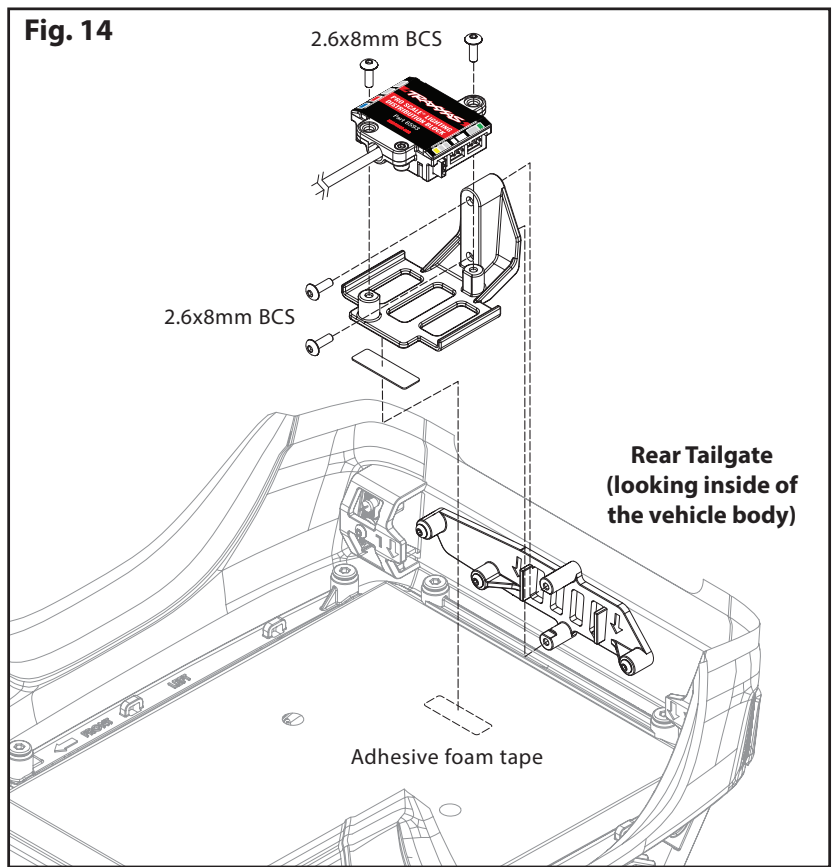

LIGHTING DISTRIBUTION BLOCK LED LIGHT HARNESS PORTS

Letter	Color	Description	Function
A	N/A	Reverse light harness	Back up light LEDs when vehicle is put in reverse
B	N/A	Rear turn signal harness	Rear turn signal LEDs
C	Red	Tail light harness	Tail light and brake light LEDs
E	Green	Rear independent turn signal jumper	Install jumper when using rear independent turn signals (separate amber LEDs)
G	White	Headlight assembly harness	Headlights and front marker light LEDs
H	White	Front turn signal harness	Front turn signal light LEDs
M	N/A	Light bar high/low harness	LED light bar that typically mounts to the roof of the vehicle
N	Yellow	Rock lights/scene lights assembly harness	Accessory LED lighting that mounts to the vehicle body or to the chassis underside (if equipped)

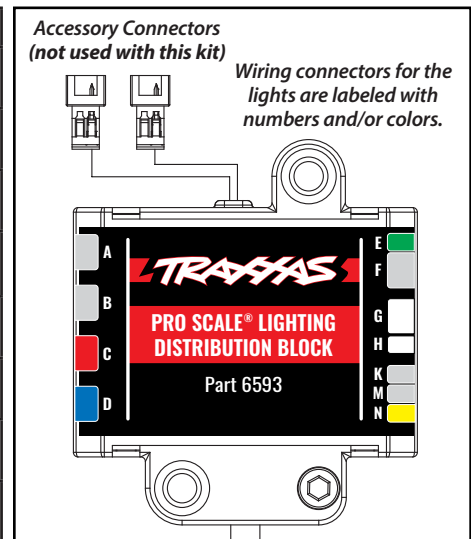

BODY WIRING DIAGRAM

Body Wiring (viewed from the underside of the body)

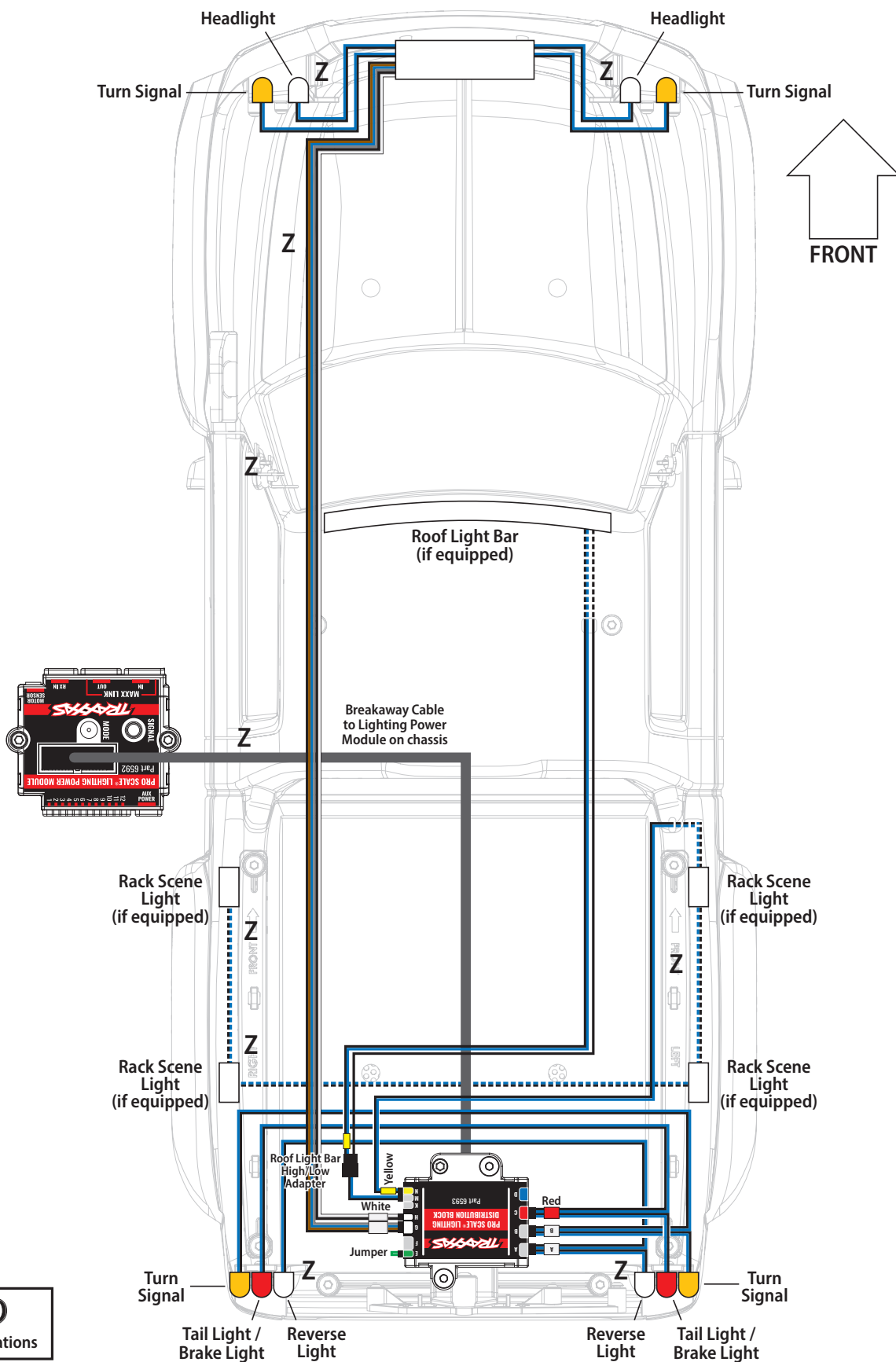

LIGHTING CONTROL SYSTEM OPERATION

HEADLIGHTS MODE SELECTION

Use the **Mode** button on the Pro Scale Lighting Power Module to cycle through the different lighting modes (from **Low Beam Mode** to **High Beam Mode** to **Daytime Mode**).

HAZARD LIGHTS

Use the **Signal** button on the Pro Scale Lighting Power Module to turn the hazard lights on or off.

TURN SIGNALS

The turn signals are activated by default. To deactivate the turn signals, press and release the **Signal** button on the Pro Scale Lighting Power Module two times quickly. Both left turn signal LEDs will blink once, and then both right turn signals LEDs will blink once to indicate that the turn signals are deactivated.

To reactivate the turn signals: Press and release the **Signal** button two times again quickly. Both left turn signal LEDs will blink twice, and then both right turn signals LEDs will blink twice to indicate that the turn signals are activated.

TURN SIGNAL OPERATION

With the vehicle stopped, turn the steering wheel on the transmitter (left or right) to turn on the LEDs. The turn signal LEDs will continue to flash while the steering wheel is turned in this same direction or remains centered. Turn the steering wheel in the opposite direction to cancel the turn signal.

	Selection	Action
Mode	Low Beam Headlights	Default
	High Beam Headlights	Press and release Mode
	Daytime Headlights (off)	Press and release Mode once again

	Selection	Action
Signal	Hazard Lights On	Press and release Signal once
	Hazard Lights Off	Press and release Signal once again
	Deactivate Turn Signals	Press and release Signal 2x quickly
	Activate Turn Signals	Press and release Signal 2x quickly again

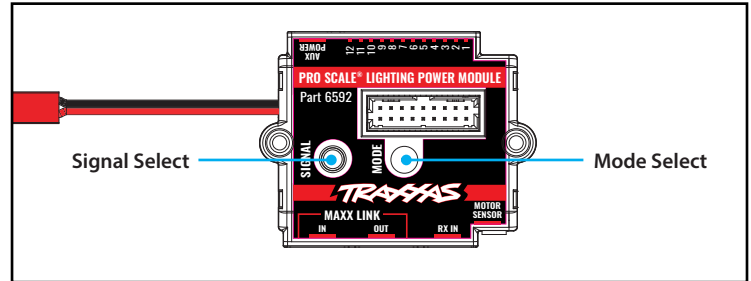

APPENDIX

WIRING DIAGRAM WITH RECEIVER COMMUNICATION CABLE AND HIGH-OUTPUT EXTERNAL BEC (part #2262, sold separately)

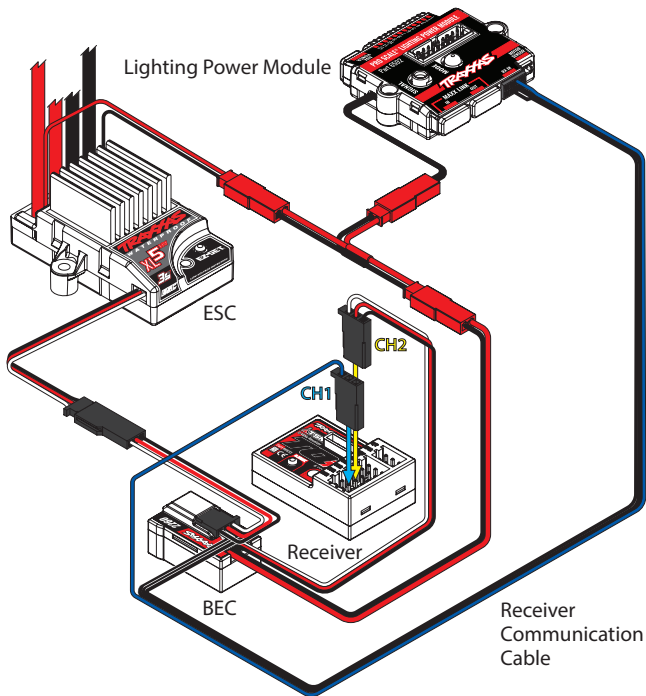

WIRING DIAGRAM WITH OPTIONAL MAXX® LINK CABLE AND HIGH-OUTPUT EXTERNAL BEC (part #2262, sold separately) (TQi Radio System Only)

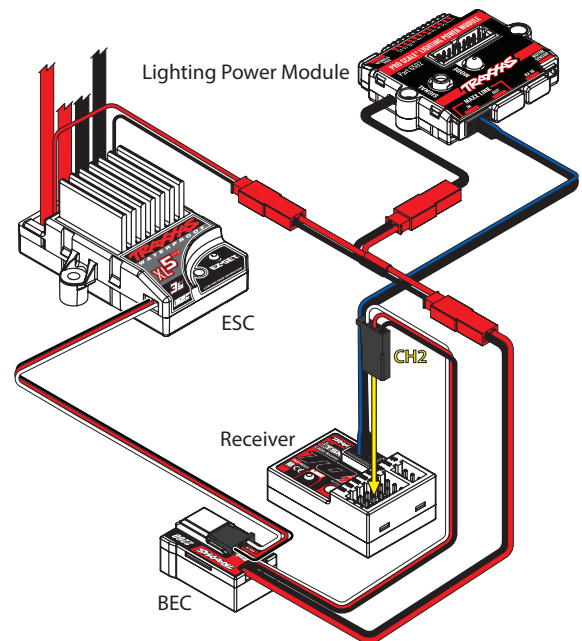

Important: To prevent possible damage to the electronics while using an external BEC, do not connect **both** the MAXX Link Cable and Receiver Communication Cable to the Lighting Power Module at the same time.

OPTIONAL MAXX LINK CABLE WIRING (TQi Radio System Only)

Use the optional included MAXX[®] Link Cable to connect the Lighting Power Module to the receiver.

DO NOT use the Receiver Communication Cable with the MAXX Link Cable. The MAXX Link Cable is designed to work with the Traxxas Link™ Wireless Module (part #6511, sold separately) to provide Traxxas Link App functionality for custom lighting controls and configurations.

Your model may require a software update for the TQi receiver via the Traxxas Link App (Traxxas Link Wireless Module required).

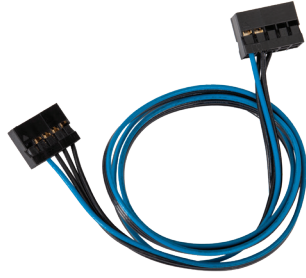

Traxxas Link Wireless Module (part #6511, sold separately)

Plug the MAXX Link cable into the **MAXX Link IN** port on the Lighting Power Module. Use the same wire routing from the Lighting Power Module and into the receiver box as shown in the Receiver Communication Cable Installation instructions. Plug the loose end of the cable into the expansion port on the receiver.

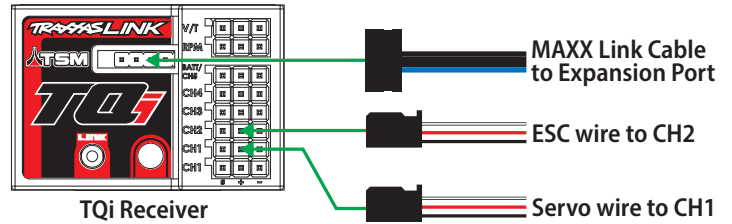

WARRANTY

Warranty Information

Traxxas electronic components are warranted to be free from defects in materials and workmanship for a period of 30 days from the date of purchase.

Limitations: Any and all warranty coverage does not cover replacement of parts and components damaged by abuse, neglect, improper or unreasonable use, crash damage, water or excessive moisture, chemical damage, improper or infrequent maintenance, accident, unauthorized alteration or modification or items that are considered consumable. Traxxas will not pay for the cost of shipping or transportation of a defective component to us.

Traxxas Lifetime Electronics Warranty

After the expiration date of the warranty period, Traxxas will repair electronic components for a flat rate. Please visit Traxxas.com/support for a current schedule of warranty costs and fees. The covered repairs are limited to non-mechanical components that have NOT been subjected to abuse, misuse, or neglect. Products damaged by intentional abuse, misuse, or neglect may be subject to additional charges. Traxxas liability, in no case, shall be greater than the actual purchase price of this product. For replacement, product must be returned in brand new condition, with packaging and itemized sales receipt.



Download and install the latest firmware updates, change the module settings, and gain access to additional functions using the Traxxas Link App (available in the Apple App StoreSM or on Google PlayTM). The TQi transmitter with the Traxxas Link Wireless Module (part #6511, sold separately) are required.



This device complies with FCC Part 15 & IC RSS-210 rules subject to the following conditions: 1) This device may not cause harmful interference, and 2) This device must accept all interference received, including interference that may cause undesired operation.

For patent and patent-pending information, please visit Traxxas.com/pat

App Store is a service mark of Apple Inc. Google Play is a trademark of Google Inc. All copyrights and trademarks are used by Traxxas under license.